

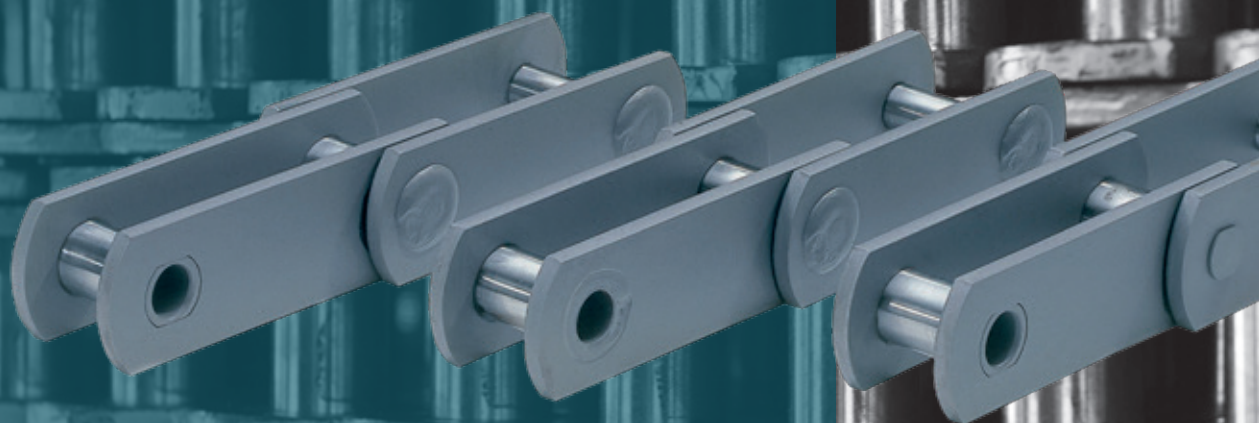

CONVEYOR CHAINS

DIN 8167 / M Series



CONVEYOR CHAINS | DIN 8167 / M Series

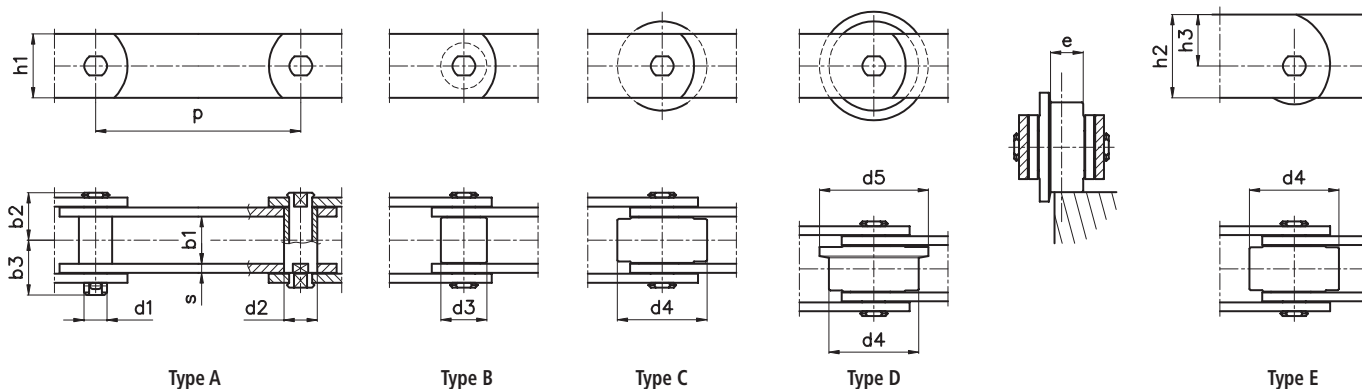

CHAIN DIN 8167	Pitch					Inner width	Pin	Bush Type B	Roller Type B	Roller Type C	Roller Type D	Sideplates				Breaking Load	Allowed Load											
	P											b ₁	d ₁	d ₂	d ₃			d ₄	d ₅	e	b ₂	b ₃	s	h ₁	h ₂	h ₃	kN	kN
	mm											mm	mm	mm	mm			mm	mm	mm	mm	mm	mm	mm	mm	mm	mm	min
M 40	63	80	100	125	160	20	8,5	12,5	18	36	42	13,5	21	24	4	25	35	22,5	40	5,7								
M 56	63	80	100	125	160	24	10	15	21	42	50	17	24	26	4	30	40	25	56	8								
M 80	80	100	125	160	200	28	12	18	25	50	60	20	28	32	5	35	50	32,5	80	11,4								
M 112	80	100	125	160	200	32	15	21	30	60	70	22	33	35	6	40	60	40	112	16								
M 160	100	125	160	200	250	37	18	25	36	70	85	25,5	38	43	7	50	70	45	160	22,8								
M 224	125	160	200	250	315	43	21	30	42	85	100	30	44	47	8	60	90	60	224	32								
M 315	160	200	250	315	400	48	25	36	50	100	120	33	51	55	10	70	100	65	315	45								
M 450	200	250	315	400	500	56	30	42	60	120	140	37	59	66	12	80	120	80	450	64								
M 630	-	250	315	400	500	66	36	50	70	140	170	45	69	74	14	100	140	90	630	90								
M 900	-	250	315	400	500	78	44	60	85	170	210	52	79	89	16	120	180	120	900	128								

- Riveted chain
- Riveted or welded chain
- Welded chain

Breaking load is 30 to 50% higher in welded construction.

UPON REQUEST

- welded pins and bushes
- sunked pin ends
- tumbled side plates (specially for plastic sliding tracks)
- other pitch or dimension
- bigger clearances
- higher breaking load
- zinc or stainless steel version
- sprockets and wheels



CONVEYOR CHAINS | DIN 8167 | WEIGHT TABLE

CHAIN DIN 8167	PITCH	CHAIN WEIGHT				
		A	B	Steel roller C	Steel roller D	Steel roller E
	P	kg/m	kg/m	kg/m	kg/m	kg/m
M40	63	2,4	2,8	4,4	4,6	4,8
	80	2,3	2,5	3,8	4	4,6
	100	2,2	2,4	3,4	3,6	3,7
	125	2	2,2	3	3,1	3,4
M56	63	3,2	3,6	6,5	6,8	7,3
	80	3	3,3	5,7	5,8	6,3
	100	2,7	3,1	4,9	5	
M80	125	2,6	2,8	4,2	4,4	
	80	4,6	5,2	9	9,3	10,3
	100	4,2	4,7	7,8	8	9,1
	125	4	4,3	6,7	7	8
M112	160	3,7	3,9	5,9	6	7,1
	80	6,7	8	13,7	11,5	16,4
	100	6,2	7	11,9	12,4	14,4
	125	5,6	6,3	10,3	10,7	12,3
M160	160	5,3	5,8	8,9	9,3	9,2
	100	9,5	10,9	18,7	19,7	21,4
	125	8,7	9,8	16	16,9	18,6
	160	8	8,9	13,7	14,4	
M224	200	7,9	8,3	12	12,6	
	125	12,8	14,6	25,5	26,8	
	160	11,8	13	21,6	22,6	
	200	10,9	11,9	19	19,6	
M315	250	10,2	11	16,5	17,1	
	160	17,9	19,9	32,8	34,5	
	200	16,4	18,5	28,5	30,3	
M450	250	15,3	16,2	24,8	25,9	
	200	24	26,7	44,2	46	
	250	22				

